



## ***Battery Cavity Design Guide***

### INTRODUCTION

Many OEM designers of battery-powered devices are unaware of the impact that battery cavity and power supply circuitry design has on consumer satisfaction. An analysis of consumer complaints received by the Duracell Consumer Relations Center indicates that very few device failures are due to battery defects. In fact, most problems can be prevented using simple precautionary measures incorporated into the design of the device and its battery cavity.

Duracell has worked with leading computer, toy, and power tool manufacturers to resolve battery cavity and power supply issues. The benefit to the original equipment manufacturer (OEM) of designing a consumer friendly battery cavity is increased customer satisfaction, which ultimately leads to increased sales.

This paper outlines important battery cavity features that should be designed into any device powered by batteries.

### Size

Frequently, OEMs design the battery cavity of their device around the battery of a single manufacturer. Unfortunately, battery dimensions often vary from manufacturer to manufacturer. For instance, the height of one manufacturer's 9-volt battery is 1.888 inches, while another's 9-volt battery measures 1.909 inches. While these differences in size do not appear to be great, the desire by OEM designers to miniaturize their devices often prevents them from leaving any excess space in the battery cavity, resulting in a cavity design that will not accept the batteries of all manufacturers.

Rather than design the battery cavity around the battery of a single manufacturer whose battery may be a unique size or configuration, it is

recommended that cavity designs be based on IEC (International Electrotechnical Commission) standards and built to accommodate maximum and minimum sizes. IEC specifications provide key battery dimensions, including overall cell height, overall cell diameter, pip diameter, pip height and diameter of negative cap. Maximum and minimum values are usually specified, as shown in Figure 1 below.

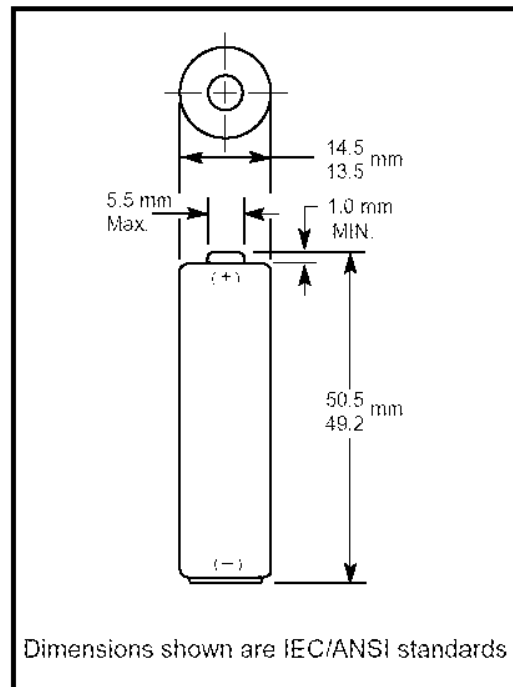

Figure 1

Along with variations in size, the battery cavity design must also be able to accommodate unusual battery configurations that fall within IEC standards. For example, several battery manufacturers offer batteries with negative recessed terminals that are designed to prevent contact when they are installed backwards. Unfortunately, negative recessed terminals will mate only with a contact whose diameter is less than the battery's positive terminal. Figure 2 illustrates the differences between cells with standard and recessed terminals.

The IEC drawings should be referenced to determine contact diameter as well as any other unusual configurations.

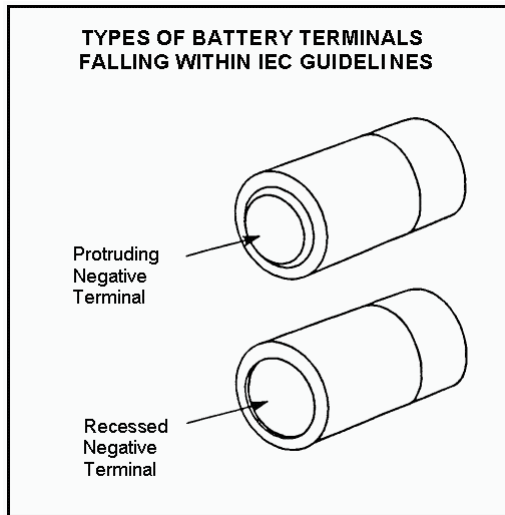

Figure 2

### **Battery Installation Instructions**

Some consumers do not have a full understanding of proper battery care, usage and installation. Manufacturers can minimize the potential for users to make common battery installation mistakes, such as mixing different battery types or inserting them backwards, by including some type of instructional message on their device.

Duracell recommends that manufacturers inscribe the following information in the battery cavity *behind the cells*: the type and size of battery, the number of cells and their orientation (see Figure 3 below).

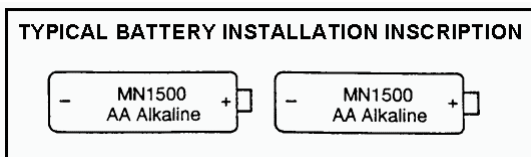

Figure 3

Additional instructions should also appear *on the battery cavity door*, such as:

1. Do not mix alkaline batteries with zinc carbon or rechargeable batteries.
2. Replace all batteries at the same time.
3. Remove fully discharged batteries immediately.

By imprinting these messages in the battery cavity and on the cavity door, the manufacturer can increase the chances of user readership since the user must open the battery cavity in order to replace the fully discharged batteries.

Another consideration is the inclination of consumers to insert batteries with the label side up, as is often the case with non-cylindrical batteries such as a 9-volt or J battery. To avoid any confusion by the consumer, it is best to design the cavity so that the battery is inserted with the label side UP.

### **Battery Contact Materials**

A variety of factors must be considered when specifying battery contacts. Several design principles apply to the substrate. The normal force provided by the contact must be great enough to hold the battery in place (even when the device is dropped) and prevent electrical degradation and resulting instability. Also, contacts must be able to resist permanent set. This refers to the ability of the contact to resist permanent deformation with a set number of battery insertions. Temperature rises, at maximum current drains due to the resistance of the alloy used, should be minimized. Excessive increases in temperature will lead to stress relaxation and loss in contact pressure, as well as to the growth of oxide films, which increase contact resistance.

Coatings are selected to satisfy criterion that the substrate does not, such as low conductivity, wear resistance, and

corrosion resistance. Gold is the optimal coating due to its ability to satisfy all of the above. However, less expensive alternatives are now available with similar properties.

Contact failure modes must be avoided, especially with inexpensive plating materials such as tin. In high humidity and polluted environments, sulfides can form on base materials and creep through pores in the coating. The sulfide film, which forms and decreases the conductivity of the contact, can be prevented with nickel under-plating. Fretting wear occurs as a result of small amplitude (130pm) oscillatory movement. The limited motion traps debris such as oxides that result from the reaction of the base material with the environment. The oxide debris decreases conductivity and can be prevented by using lubricants (i.e., polyphenylethers, perfluoroalkylpolyethers, and polyphenylether microcrystalline wax mixtures).

The following is a list of contact materials recommended for use with DURACELL Batteries:

*Gold Plating -Provides the most reliable metal-to-metal contact under all environmental conditions.*

*Nickel (Solid) -Provides excellent resistance to environmental corrosion and is second only to gold plating as a contact material. Solid nickel can be drawn or formed.*

*Nickel Clad Stainless -Performs almost as well as solid nickel with excellent resistance to corrosion.*

*Nickel-Plated Stainless -A widely used material. Non-plated stainless steel is not recommended due to the adverse impact of passive films, which develop on the surface and result in poor electrical contact.*

*Inconel Alloy -Provides good electrical conductivity and good corrosion resistance. However, soldering may be difficult unless an active flux is used.*

*Nickel-Plated Cold-Rolled Steel – An economical contact material that provides good contact surface for welding and soldering. A continuous, non-porous nickel plating of 200 micro-inches is recommended.*

A manufacturer of battery contacts should be contacted for further information on these and other contact materials.

### **Contact Design**

The greatest number of battery complaints received by Duracell is from users who have inserted the batteries backwards. This error can result in the charging of batteries, leading to venting and leakage.

Reverse installation of cells can be easily avoided by using a battery terminal design to prevent contact if batteries are installed backwards. Two simple solutions are depicted in Figures 4a and 4b.

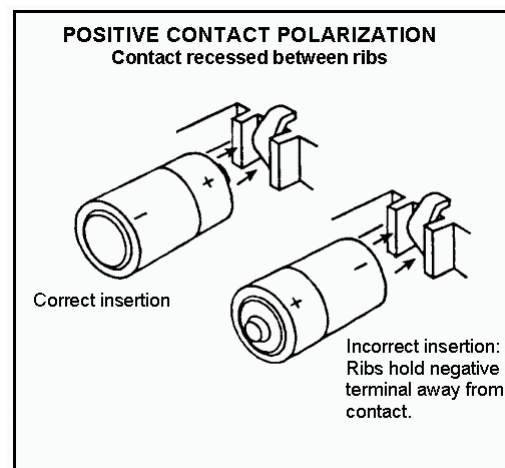

Figure 4a

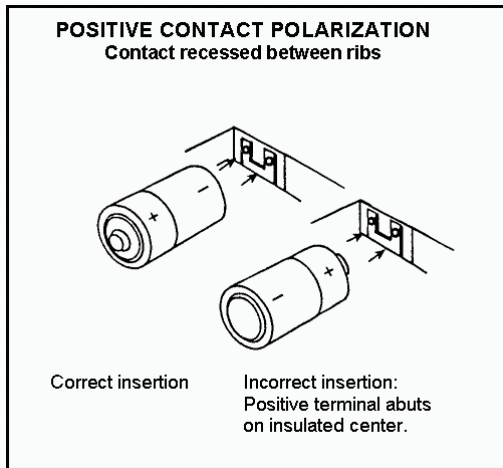

Figure 4b

The following is a list of several types of battery terminals which are available:

*Miniature Snap Terminals - Recommended when the battery will be changed often.*

*Printed Circuit Board Pins - Used when the battery is a permanent component.*

*0.005" Flat Nickel Tab Stock - Used for a permanent soldered connection.*

*Single Point Spring or Clip - For use with miniature cells or a low current drain. Material must provide a spring pressure of 50 to 80 grams (0.49 to 0.78 N) on small button cells. (Caution should be taken to prevent denting cells with excessive pressure.)*

*Multiple Point Contact - Desirable for higher current drains. For larger cylindrical cells, a pressure of 150 to 175 grams (1.47 to 1.72 N) is recommended. Contact point is divided into several individual points or prongs.*

*Standard Electrical Connector - Terminals made by a contact manufacturer.*

A manufacturer of battery contacts should be contacted for further information on these and other types of contacts.

### Prismatic Battery Contacts

Prismatic batteries like the CP1 (LiMnO<sub>2</sub>) have for contacts nickel tabs, recessed around 1mm from the battery top. They are shown as small square windows on fig. 5, along with the size-matching rechargeable NP-60 (Li-ion) battery. The battery contacts need to have sufficient travel to penetrate the recess and apply sufficient contact pressure to minimize contact resistance. Minimum travel of 2.5 mm and minimum force of 200 grams are used to assure reliable performance in high-drain devices.

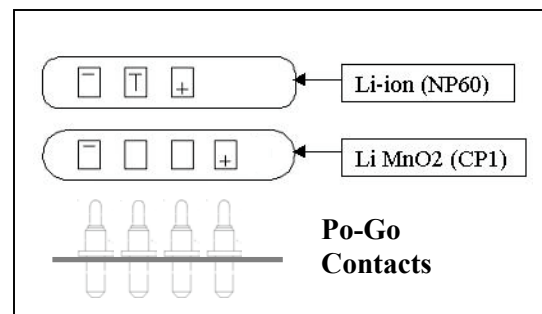

Figure 5

Gold-plated Po-Go contacts meet all of the above requirements.

### Ventilation

There are three conditions that will cause alkaline batteries to generate hydrogen gas. The first, a natural oxidation process, occurs even when the battery is left idle. Here, oxidation of the zinc prompts a release of hydrogen from the electrolyte. These gasses escape through the crimp and nail hole as well as permeate through the plastic grommet. A second process occurs when batteries are discharged below a safe cutoff voltage. Electrolysis results when the manganese dioxide is depleted and excess zinc and water

remain. The gasses could possibly "vent" in this situation. Venting is the release of gas pressure through a vent that is designed into the battery for safety purposes. Leakage of electrolyte will almost always occur during venting. The third process -- charging -- can generate a large volume of gas in a short period of time. This happens when a reverse current is forced through the battery or the battery is inserted backwards. This situation could also cause the gasses to vent from the cell.

All three conditions must be accounted for in any device design. Battery cavity ventilation should be provided to accommodate low rate gassing from oxidation and abusive usage of batteries. Tables 1 and 2 provide an estimate of the amount of gas generated in each situation for selected batteries. Actual values will vary due to the construction of the battery and the materials used.

Lithium Cell Type	Gas (Methane) Generated During Overdischarge/Charge
2/3A	< 0.2 ml
1/3N	< 0.2 ml

Table 1

Alkaline Cell Type	Gas Generated by Oxidation	Gas Released During Overdischarge/Charge
D	< 0.29 ml/day	120 ml
C	< 0.17 ml/day	55 ml
AA	< 0.05 ml/day	20 ml
AAA	< 0.01 ml/day	10 ml

Table 2

Ventilation may be difficult in certain applications, such as underwater flashlights, where the device must be waterproof. In these cases, polypropylene, polyethylene, or some

other gas permeable material should be considered. The device enclosure itself could be made of this material or a membrane of the material of a certain area can be designed into the enclosure.

The amount of gas to be released is related to the area and thickness of the material. For instance, a 2mm thick polypropylene membrane area of 0.07cm<sup>2</sup> is sufficient for each AA alkaline battery used.

Gassing can be minimized by preventing abusive over-discharge or charge conditions. Please contact Duracell for the recommended cutoff voltages for each battery type. Reverse installation should also be prevented as mentioned in the above section on contact design. Please contact Duracell for further information and design assistance.

### Positioning

The following guidelines apply to positioning the battery cavity within the device. First, the battery cavity should be isolated from the electronic circuitry, since the metal can in which the battery chemicals are enclosed is an active part of the circuitry. If electronic components come in contact with the battery and pierce the battery label, failure of the device may occur.

Second, extra care should be taken to isolate the battery from heat sinks and exhaust air flow since heat generated by the electronics will shorten the service life of the battery.

Lastly, the battery cavity should be designed to contain any leakage that might occur under abusive conditions, thus preventing harm to the electronics. As an option, the battery cavity could be located at the bottom of the device so any leaking electrolyte would fall conveniently away from the circuitry.

### Accessibility

The battery cavity should be easily accessible to the user, with the exception of those devices intended for use by children. Since small children often place objects (such as batteries) in their mouths, the battery cavity should be designed to open only with the aid of a coin or key to prevent access to the batteries by children.

### Configuration

A series and/or parallel connection of batteries within the battery cavity is often desired to increase voltage and/or capacity. When series and/or parallel connections are used, accidental charging can occur if a battery is inserted backward, even when the device is turned off. Thus, terminals that prevent the reverse installation of batteries are mandatory for series and/or parallel connections. As well, care should be taken to illustrate proper insertion of the cells through the use of a drawing or diagram in the cavity. Diagrams of series, parallel and series/parallel connections are shown in Figures 6a and 6b.

If terminals to prevent reverse installation are *not* used, the number of cells used in a device should be limited, with consideration given to a worst-case scenario where a battery is inserted backward and thus charged. The number of cells employed should allow the end-user enough time to turn the device on, determine that it is working improperly, and take corrective action. The greater the number of cells used, the larger the potential applied across the single reversed cell and the shorter the time to venting.

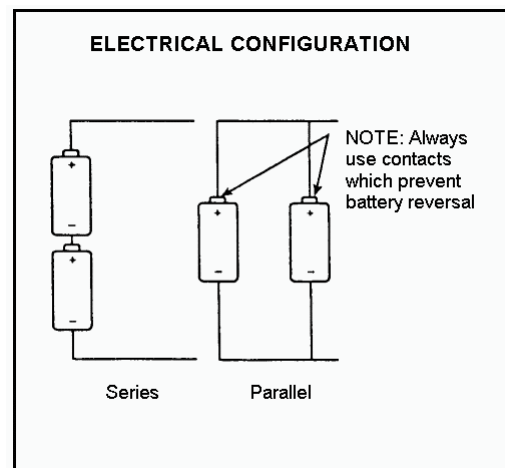

Figure 6b

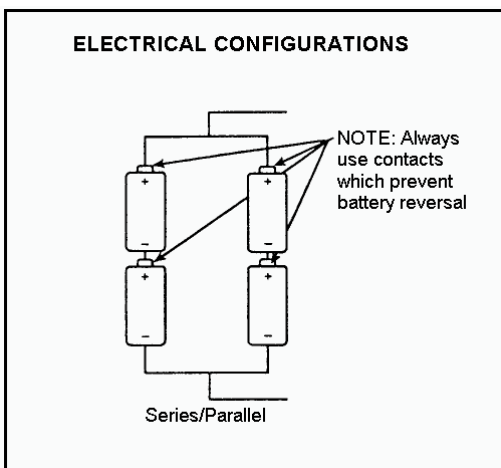

Figure 6a

Four cells are a desirable quantity, given that one fresh cell charged by three others takes roughly two minutes to vent. Again, the use of terminals designed to prevent the reverse installation of batteries will seriously diminish this threat and allow for the use of larger numbers of batteries.

### Cutoff Voltages

Electrolysis occurs when batteries are deeply discharged. The gas produced in this reaction will eventually lead to venting. Therefore, the cutoff voltage

should be set above the level at which this reaction becomes potent. Refer to the specific battery data sheet or Duracell technical bulletin to find the recommended cutoff voltage for each cell chemistry. Eight-tenths of a volt per cell is the minimum cutoff voltage for alkaline cells. Figure 7 illustrates the chemical reactions that take place during the discharge of an alkaline cell. Below 0.8V the battery is prone to gassing.

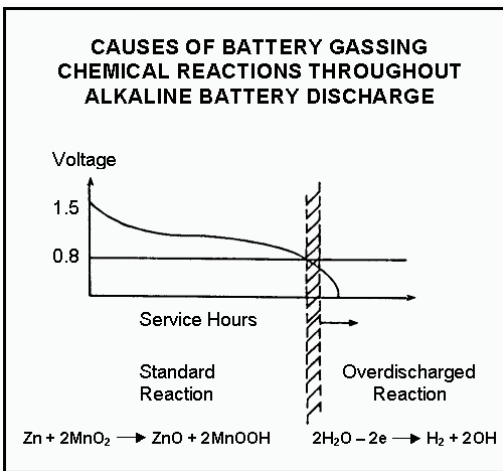

Figure 7

Other factors need to be considered when setting a cutoff voltage. For instance, in a situation where a user mixes old and new batteries, the old battery can easily reach deep discharge. To prevent this condition from becoming harmful, the number of cells across which the voltage is monitored must be limited. A maximum of five cells per monitored string is a safe guideline. To demonstrate this, Duracell recently tested batteries in a computer requiring ten AA alkaline batteries and operating at current drains from 0.5 to 1 amp. The voltage was monitored over two five-cell strings. One of the ten cells in series was previously discharged 90 percent.

For test purposes, the voltage across this one cell was also monitored. Figure 8 shows the voltage across this cell. Even though the voltage of the pre-discharged cell dropped quickly, the 4-volt cutoff for the five cells (0.8 volt per cell) enabled the computer to shut down fast enough to prevent venting.

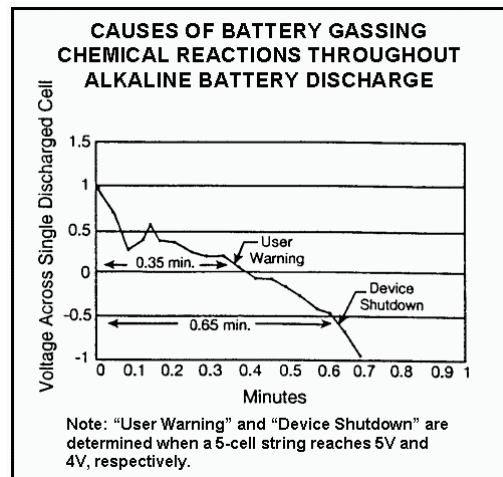

Figure 8

Many devices work in multiple modes, each with different power requirements, as shown in Figure 9. For instance, standby and alert modes are found in pagers. The cutoff voltage used for these devices must reflect the battery's voltage in the higher drain modes. This safeguard prevents the device from shutting down when the high drain mode is entered. Therefore, the voltage of the battery in each of the multiple modes must be understood throughout the life of the battery. This allows the designer to reference cutoff values for high drain modes to load voltages at lower rate modes. Device software should be set to prevent the user from switching to high rate modes when the battery's voltage falls below critical thresholds. The device should shut down once the cutoff voltage for the lowest useful rate mode is attained.



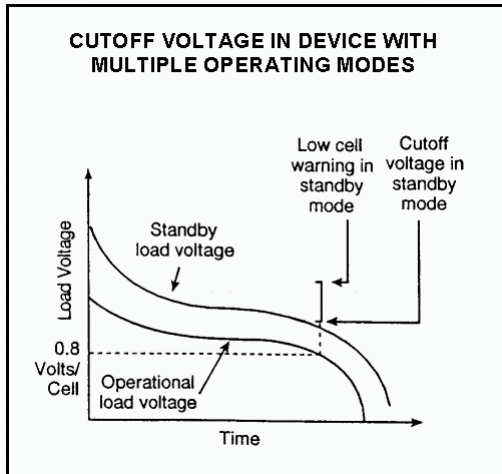

Figure 9

### **Charging Protection**

Charging of primary batteries should be avoided. Duracell has evaluated several devices that offer both primary battery and AC power options. In these devices, mechanical switches are preferred over electrical versions (i.e., diodes, MOSFETs) due to the absence of leakage current and forward voltage drop.

Lithium batteries will allow small amounts of leakage current. For information on the use of diodes with lithium batteries, please refer to the Duracell Lithium Technical Bulletin, Section 7, or contact Duracell for technical assistance.

### **SUMMARY**

Prior to the final design of any battery-operated device, the battery cavity should be tested under worst case conditions. Typical scenarios include repeated usage and exposure to high heat and humidity. Key battery cavity parameters should be checked, such as corrosion on battery terminals and the ability of the cavity to vent gasses emitted by the battery. Tests should be performed which take into consideration

the above variables to ensure optimum battery-to-device fit and performance.

Original equipment manufacturers are advised to work closely with a major battery manufacturer capable of providing technical assistance on both the battery and its usage. Duracell encourages OEMs to consult their nearest Duracell sales office for further information.

### **CAUTION**

This guide is intended for general information only and the material contained herein may be inapplicable or incomplete if applied to certain specific battery applications. All device designs should be fully tested to take into consideration any battery operating variables and to insure optimum battery-to-device fit, performance and safety. Duracell assumes no responsibility for specific device designs as related to battery usage or otherwise.