

Understanding Linear Power Supply Operation

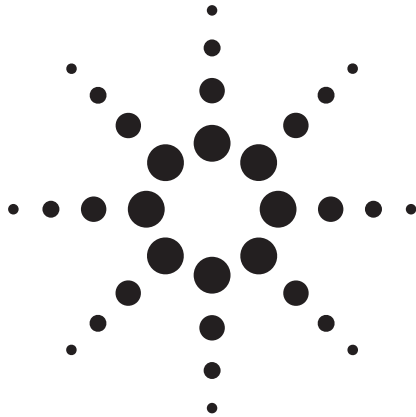

Application Note 1554

Contents

Overview of linear power supply operation / 2

Output characteristics / 3

Extending the voltage and current range / 5

Remote programming / 6

This application note describes the basic operation of linear power supplies. You will also find information to help you better understand output characteristics of a linear power supply compared to an ideal supply.



Overview of linear power supply operation

The basic design model for a power supply consists of a control element in series with a rectifier and load device. **Figure 1** shows a simplified schematic of a series-regulated supply with the phase-controlled pre-regulator depicted as a power switch and the series element depicted as a variable resistor. The phase-controlled pre-regulator minimizes the power dissipated at the series element by maintaining a low and constant voltage drop across the series element. Feedback control circuits continuously monitor the output and adjust the series resistance to maintain a constant output voltage. The variable resistance series element of the supply shown in **Figure 1** is actually produced by one or more power transistor operating in the linear (class A) mode; supplies with this type of regulator are often called linear power supplies. Linear power supplies have many advantages. Because they provide sufficient power with stable regulation and little noise, they usually are the simplest, most effective solution for providing bench power.

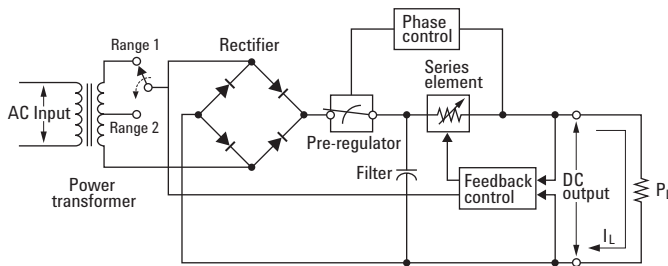

Figure 1. Diagram of simple series power supply

The power supply shown in **Figure 1** has two ranges, allowing more voltage at a lower current or more current at a lower voltage. Single-range supplies can output maximum power only at full-scale voltages and full-scale current. A linear supply can provide output power that is close to maximum at full scale for both ranges. The pre-regulator in this power supply uses solid-state transformer tap switches on the secondary winding of the power transformer. This technique is very effective in reducing the power dissipated in the series element.

In terms of performance, a linear regulated supply has very precise regulating properties and responds quickly to variations of the line and load. Hence, its line and load regulation and transient recovery time are superior to supplies using other regulation techniques. A linear power supply also exhibits low ripple and noise, tolerates ambient temperature changes, and is highly reliable due to its circuit simplicity.

The linear regulator is controlled by a DAC driven by a digital circuit that provides a voltage proportional to the program voltage. The power supply sends back to the control circuits a voltage representing the output at the terminals. The control circuits receive information from the front panel and send information to the display. Similarly, the control circuits “talks” to the remote interface for input and output with the GPIB, RS-232, USB, or LAN interfaces. The remote interface is at earth ground and is optically isolated from the control circuit and the power supply.

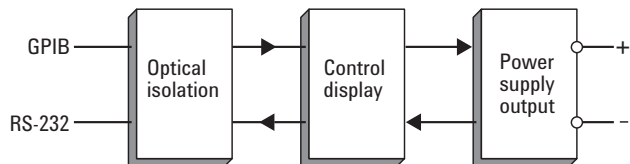

Figure 2. Block diagram of the power supply showing the optical isolation

Output characteristics

An ideal constant-voltage power supply would have zero output impedance at all frequencies. Thus, as shown in **Figure 3**, the voltage would remain perfectly constant in spite of any changes in output current demanded by the load.

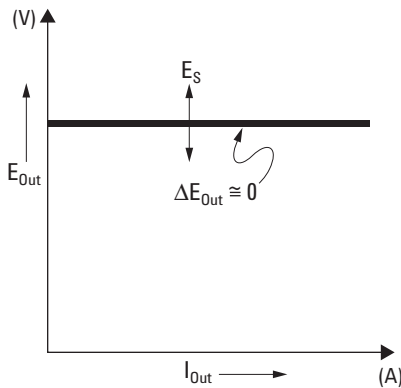

Figure 3. Ideal constant-voltage power supply

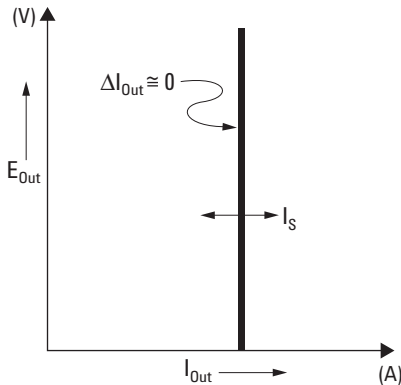

Figure 4. Ideal constant-current power supply

The ideal constant-current power supply exhibits infinite output impedance at all frequencies. Thus, as **Figure 4** indicates, the ideal constant-current power supply would accommodate a load resistance change by altering its output voltage by just the amount necessary to maintain its output current at a constant value.

The output of this power supply can operate in either constant-voltage (CV) mode or constant-current (CC) mode. Under certain fault conditions, the power supply cannot operate in either CV or CC mode and becomes unregulated.

Figure 5 shows the operating modes of the output of this power supply. The operating point of one supply will be either above or below the line $R_L = R_C$. This line represents a load where the output voltage and the output current are equal to the voltage and current setting. When the load R_L is greater than R_C , the output voltage will dominate since the current will be less than the current setting. The power supply is said to be in constant voltage mode. The load at point 1 has a relatively high resistance value (compared to R_C), the output voltage is at the voltage setting, and the output current is less than the current setting. In this case, the power supply is in the constant voltage mode and the current setting acts as a current limit.

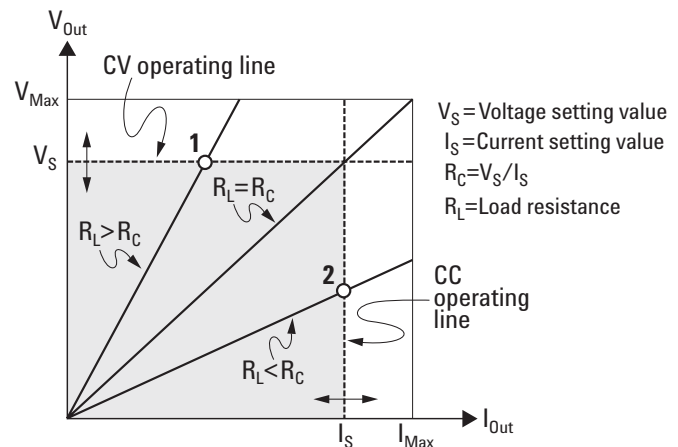

Figure 5. Output characteristics

When the load R_L is less than R_C , the output current will dominate since the voltage will be less than the set voltage. The power supply is said to be in constant current mode. The load at point 2 has a relatively low resistance, the output voltage is less than the voltage setting, and the output current is at the current setting. The supply is in constant current mode and the voltage setting acts as a voltage limit.

Unregulated state

If the power supply should go into a mode of operation that is neither CV nor CC, the power supply is unregulated. In this mode the output is not predictable. The unregulated condition may be the result of the AC line voltage below the specifications. The unregulated condition may occur momentarily. For example, when the output is programmed for a large voltage step, the output capacitor or a large capacitive load will charge up at the current limit setting. During the ramp up of the output voltage the power supply will be in the unregulated mode. During the transition from CV to CC, as when the output is shorted, the unregulated state may occur briefly during the transition.

Unwanted signals

An ideal power supply has a perfect DC output with no signals across the terminals or from the terminals to earth ground. An actual power supply has finite noise across the output terminals and a finite current will flow through any impedance connected from either terminal to earth ground. The first is called normal mode voltage noise and the second common mode current noise. **Figure 6** shows a simplified diagram of common mode and normal mode sources of noise.

Normal mode voltage noise is in the form of ripple related to the line frequency plus some random noise. Both of these are very low in a quality bench power supply. Careful lead layout and keeping the power supply circuitry away from power devices and other noise sources will keep these values low.

Common mode noise can be a problem for very sensitive circuitry that is referenced to earth ground. When a circuit is referenced to earth ground, a low-level current related to the AC line will flow from the output terminals to earth ground. Any impedance to earth ground will create a voltage drop equal to the current flow multiplied by the impedance. To minimize this effect, the output terminal can be grounded at the output terminal. Alternately, any impedance to earth ground should have complementary impedance to earth ground to cancel any generated voltages. If the circuit is not referenced to earth ground, common mode power line noise is typically not a problem.

The output will also change due to changes in the load. As the load increases, the output current will cause a small drop in the output voltage of the power supply due to the output impedance (R). Any resistance in the connecting wire will add to this resistance and increase the voltage drop. You can minimize the voltage drop by using the largest possible hook up wire. Using the remote sense leads at the load will compensate for lead resistance in the load leads.

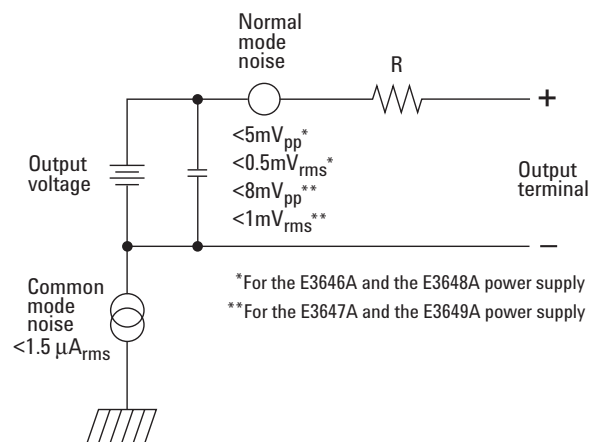

Figure 6. Simplified diagram of common mode and normal mode

When the load changes very rapidly, as when a relay contact is closed, the inductance in the hook-up wire and in the power supply output will cause a spike to appear at the load. The spike is a function of the rate of change of the load current. When you expect very rapid changes in load, you can minimize these voltage spikes by using a capacitor with a low series resistance, in parallel with the power supply and close to the load.

Extending the voltage and current range

A power supply may be able to provide voltages and current greater than its rated maximum outputs if the power-line voltage is at or above its nominal value. Operation can be extended typically up to 3% over the rated output without damage to the power supply, but performance cannot be guaranteed to meet specifications in this region. If the power-line voltage is maintained in the upper end of the input voltage range, the power supply will probably operate within its specifications. A power supply is more likely to stay within specifications if only one of the voltage or current outputs is exceeded.

Series connections

If you need a higher voltage than you can get from a single supply, you can operate two or more power supplies in series up to the output isolation rating of any one supply. You can operate series-connected power supplies with one load across both power supplies or with a separate load for each power supply. A quality bench power supply has a reverse polarity diode connected across the output terminals so that if you operate it in series with other power supplies, damage will not occur if the load is short-circuited or if one power supply is turned on separately from its series partners.

When you use series connection, the output voltage is the sum of the voltages of the individual power supplies. The current is the current of any one power supply. You must adjust each of the individual power supplies to obtain the total output voltage.

Parallel connections

If you have power supplies capable of CV/CC automatic crossover operation, you can connect two or more of them in parallel to obtain a total output current greater than that available from one power supply. The total output current is the sum of the output currents of the individual power supplies. You can set the output of each power supply separately. The output voltage controls of one power supply should be set to the desired output voltage; the other power supply should be set for a slightly higher output voltage. The supply with the higher output voltage setting will deliver its constant current output and drop its output voltage until it equals the output of the other supply, and the other supply will remain in constant voltage operation and only deliver that fraction of its rated output current that is necessary to fulfill the total load demand.

Remote programming

During remote programming a constant-voltage regulated power supply is called upon to change its output voltage rapidly. The most important factor limiting the speed of output voltage change is the output capacitor and load resistor.

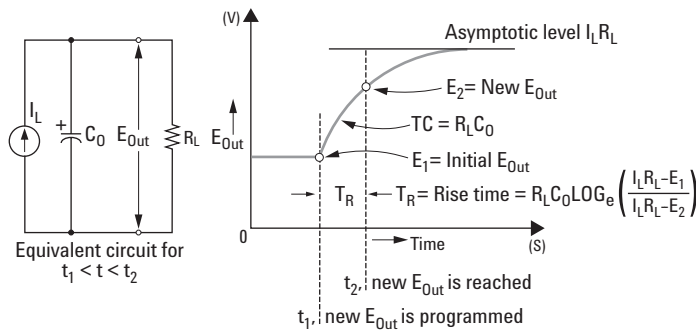

Figure 7. Speed of response — programming up (full load)

In **Figure 7**, you can see the equivalent circuit and the nature of the output voltage waveform when the supply is being programmed upward. When the new output is programmed, the power supply regulator circuit senses that the output is less than desired and turns on the series regulator to its maximum value I_L , the current limit or constant current setting.

This constant current I_L charges the output capacitor C_0 and parallel load resistor R_L . The output therefore rises exponentially with a time constant $R_L C_L$ towards voltage level $I_L R_L$, a value higher than the new output voltage being programmed.

When this exponential rise reaches the newly programmed voltage level, the constant voltage amplifier resumes its normal regulating action and holds the output constant. Thus, the rise time can be determined approximately using the formula shown in **Figure 7**.

If no load resistor is attached to the power supply output terminal, then the output voltage will rise linearly at a rate of C_0 / I_L when programmed upward, and $T_R = C_0 (E_2 - E_1) / I_L$, the shortest possible up-programming time.

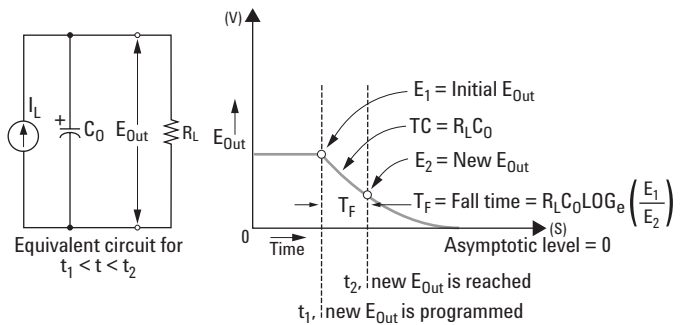

Figure 8. Speed of response — programming down

Figure 8 shows that when the power supply is programmed down, the regulator senses that the output voltage is higher than desired and turns off the series transistors entirely. Since the control circuits cannot cause the series regulator transistors to conduct backwards, the output capacitor can only be discharged through the load resistor and internal current source (I_S).

The output voltage decays linearly with slope of I_S / C_0 with no load and stops falling when it reaches the new output voltage, which has been demanded. If full load is connected, the output voltage will fall exponentially faster.

Since up-programming speed is aided by the conduction of the series-regulating transistor, while down programming normally has no active element aiding in the discharge of the output capacitor, bench power supplies normally program upward more rapidly than downward.

Glossary

Auto range – When the power supply's regulator uses a variable voltage source, the lower the voltage source the more current can be output by the power supply. The power supply picks the lowest internal voltage source to meet the output voltage requirement in order to supply the maximum current. An auto-range supply can cover more current combinations than a single- or dual-range supply

Common mode noise – Noise that travels through a ground loop

Constant current mode – A CV/CC power supply cannot be set to output a constant current. Instead, the current limit needs to be set below the current drawn by the load. Once a power supply has switched from regulating the output voltage to limiting the current, it is in a constant current mode.

Constant voltage mode – The power supply will output the programmed voltage with a varying load unless the output current rises above the programmed current setting.

Down programming – Setting the power supply's output voltage to a smaller value. The power supply is forced to sink current.

Dual range – Output voltage is generated from two internal voltage sources. The lower-voltage source can generate more current. A dual power supply can cover more voltage current combinations than a single-range supply.

Ideal constant-current power supply – A supply with infinite output impedance; the supply will output the program current under any load

Ideal constant voltage power supply – A supply with zero output impedance; the supply will output the program voltage under any load

Linear supply – To regulate the output, one or more power transistors are used to reduce the output voltage to the proper value. The power transistors operate in linear (class A) mode.

Normal mode noise – Noise that flows in the same direction as the power from the supply

Output voltage – Voltage measured at the output terminals. Using remote sense will increase the output voltage above the program voltage to compensate for the voltage drop in the leads.

OVP – Over voltage protection, an independent circuit used to clamp the output voltage, protecting the load

Program voltage – Voltage set via the front panel, remote interface or analog programming terminals

Ripple and noise – The AC component of a power supply output; both the RMS value and the peak value should be specified

Settling time – Time required for the output to reach the programmed voltage

Single range – The output can be characterized as having a max voltage and a max current. A single range supply can output any voltage/current combination within these limits.

Speed of response – The time it takes to change from one voltage to a new program voltage

Transient response – The time required for the output voltage to recover from a change in load

Unregulated state – If the power supply should go into a mode of operation that is neither CV nor CC, the power supply is unregulated. In this mode the output is not predictable.

Related Agilent literature

Publication title	Publication type	Publication number	Web address
E3631A, E3632A, E3633A, and E3634A Bench Power Supplies	Data sheet	5968-9726EN	http://cp.literature.agilent.com/litweb/pdf/5968-9726EN.pdf
E3640A - E3649A DC Power Supplies	Data sheet	5968-7355EN	http://cp.literature.agilent.com/litweb/pdf/5968-7355EN.pdf
E3610A - E3630A Manual Power Supplies	Data sheet	5968-9727EN	http://cp.literature.agilent.com/litweb/pdf/5968-9727EN.pdf



Agilent Email Updates

www.agilent.com/find/emailupdates

Get the latest information on the products and applications you select.

Agilent T&M Software and Connectivity

Agilent's Test and Measurement software and connectivity products, solutions and developer network allows you to take time out of connecting your instruments to your computer with tools based on PC standards, so you can focus on your tasks, not on your connections.

Visit www.agilent.com/find/connectivity for more information.

By internet, phone, or fax, get assistance with all your test & measurement needs.

Online assistance:
www.agilent.com/find/assist

Phone or Fax

United States:

(tel) 800 829 4444
(fax) 800 829 4433

Canada:

(tel) 877 894 4414
(fax) 800 746 4866

China:

(tel) 800 810 0189
(fax) 800 820 2816

Europe:

(tel) (31 20) 547 2111
(fax) (31 20) 547 2390

Japan:

(tel) (81) 426 56 7832
(fax) (81) 426 56 7840

Korea:

(tel) (82 2) 2004 5004
(fax) (82 2) 2004 5115

Latin America:

(tel) (650) 752 5000

Taiwan:

(tel) 0800 047 866
(fax) 0800 286 331

Other Asia Pacific Countries:

(tel) (65) 6375 8100
(fax) (65) 6836 0252
Email: tm_ap@agilent.com

Product specifications and descriptions in this document subject to change without notice.
02/04/2005

