

Pressure Sensor

Force/Pressure Transducer

Model 1865 Series

FEATURES

- Silicon pressure/force interface diaphragm
- Force measurement for infusion pump applications
- Pressure measurement for liquid media
- Medical-grade materials
- 8-pin DIP electrical connection
- Laser trimmed
- Choice of voltage or constant current excitation

TYPICAL APPLICATIONS

- Infusion pumps
- Anesthesia monitors
- Non-corrosive, non-pressurized media-level sensors
- Ventilation systems
- Blood pressure equipment
- Syringe pumps
- Drug delivery systems

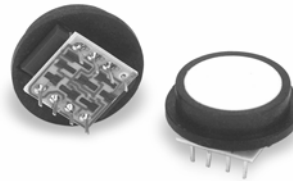

The Model 1865 is a high-performance transducer specifically designed to address the needs of medical and specialized OEM applications. Offering laser-trimmed compensation, the Model 1865 may be specified to operate with either a constant current or voltage supply.

The Model 1865 employs a solid state piezoresistive pressure transducer mounted in a plastic package. For applications where force is applied by a flexible membrane to the sensor, such as found in infusion pumps, the Model 1865's precision height silicone diaphragm provides long life and is a reliable replacement for older force or load cell transducers. Utilizing a silicon rubber diaphragm, the 1865 is compatible with some liquid media applications.

The Model 1865 provides access to important safety features in critical care medical instrumentation, such as occlusion pressure or infiltration detection. The pressure data can provide medical personnel with useful diagnostic information regarding the condition of the patient's circulatory system. These force/pressure transducers can also be used with other medical dispensing devices, such as syringe pumps, to improve safety and accuracy.

May be operated in either current or voltage excitation, the Model 1865's output can be amplified or signal conditioned, as required. The semiconductor-based sensor offers high resolution using its Wheatstone Bridge strain gauge design. The height of the unit's patented, poured-in-place silicon rubber diaphragm is controlled to ensure sensitivity to low pressure. This diaphragm is bonded to a plastic header and transmits force applied through a special silicone gel to the diaphragm of a silicon piezoresistive die. The back of the die is exposed to atmospheric pressure, which results in a gauge pressure output.

⚠ WARNING

PERSONAL INJURY

DO NOT USE these products as safety or emergency stop devices or in any other application where failure of the product could result in personal injury.

Failure to comply with these instructions could result in death or serious injury.

⚠ WARNING

MISUSE OF DOCUMENTATION

- The information presented in this product sheet is for reference only. Do not use this document as a product installation guide.
- Complete installation, operation, and maintenance information is provided in the instructions supplied with each product.

Failure to comply with these instructions could result in death or serious injury.

Pressure Sensors

Force/Pressure Transducer

Model 1865 Series

ELECTRICAL SPECIFICATIONS

| | Ratings |
|-----------------------------|--------------------------------|
| Input impedance | |
| Current excitation | 2.0 KOhm min. to 8.0 KOhm max. |
| Voltage excitation | 8.0 KOhm min. to 40 KOhm max. |
| Output impedance | |
| Current excitation | 3.5 KOhm min. to 6.0 KOhm max. |
| Voltage excitation | 3.5 KOhm min. to 6.0 KOhm max. |
| Input excitation | |
| Current | < 2.0 mA |
| Voltage | < 15.0 Vdc |
| Effect of excitation change | Ratiometric |
| Response time (10% to 90%) | ≤ 5 milliseconds |
| Insulation resistance | ≥ 100 MOhm at 50 Vdc |
| Output common mode voltage | 50 % of input typical |

PHYSICAL SPECIFICATIONS

| | Specification |
|--------------------------------|---|
| Pressure over-range protection | 3X span or 60 psi, whichever is least |
| Media/materials compatibility | |
| Top side | Room atmosphere, directly applied force, and liquids compatible with dimethyl silicon, polyetherimide (Ultem) |
| Bottom side | Non-corrosive dry gasses and fluids compatible with silicon, Pyrex, RTV silicone, and ceramic |
| Mass | 3.0 g with laser-trim board |

ENVIRONMENTAL CONDITIONS

| | Specification |
|------------------|--|
| Position effect | ≤ 0.05 % of zero or span shift for 90° tilt in any direction |
| Vibration effect | No change in performance at 10 Gs RMS, 20 Hz to 2,000 Hz |
| Shock | 100 Gs for 11 milliseconds |
| Life | 1 million cycles |

PERFORMANCE SPECIFICATIONS

| | Min. | Typ. | Max. | Unit |
|--|------------------------------------|--------|-------|---|
| Temperature Compensated Performance | | | | |
| Nonlinearity | - | 0.10 | 0.25 | % of Span, BFSL |
| Hysteresis | - | 0.0125 | 0.015 | % of Span, BFSL |
| Repeatability | - | 0.0125 | 0.015 | % of Span, BFSL |
| Output (laser trimmed normalized) | | | | |
| Current excitation | 98 | 100 | 102 | mVdc |
| Voltage Excitation | 38 | 40 | 42 | mVdc |
| Zero pressure | -2 | 0 | 2 | mVdc |
| Temperature Performance | | | | |
| Compensated temperature range | -1 °C to 54 °C [30 °F to 129 °F] | | | |
| Operating temperature range | -28 °C to 54 °C [-19 °F to 129 °F] | | | |
| Maximum zero error | | | 0.5 | % of Span in reference to 27 °C [80.6 °F] |
| Maximum span error | | | 0.5 | % of Span in reference to 27 °C [80.6 °F] |
| Thermal hysteresis | | | 0.2 | % of Span, compensated temperature range |
| Long-term stability | | | ± 0.3 | % of Span per six months |

Pressure Sensors

Force/Pressure Transducer

Model 1865 Series

FIGURE 1. LASER TRIM BOARD

Current Excitation, Normalized Output

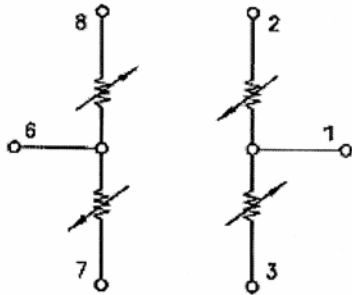

| Pin | Connection | Pin | Connection |
|-----|------------|-----|------------|
| 1 | + Output | 5 | + Input |
| 2 | NC | 6 | - Output |
| 3 | - Input | 7 | NC |
| 4 | NC | 8 | NC |

FIGURE 2. DIMENSIONAL DRAWING (FOR REFERENCE ONLY)

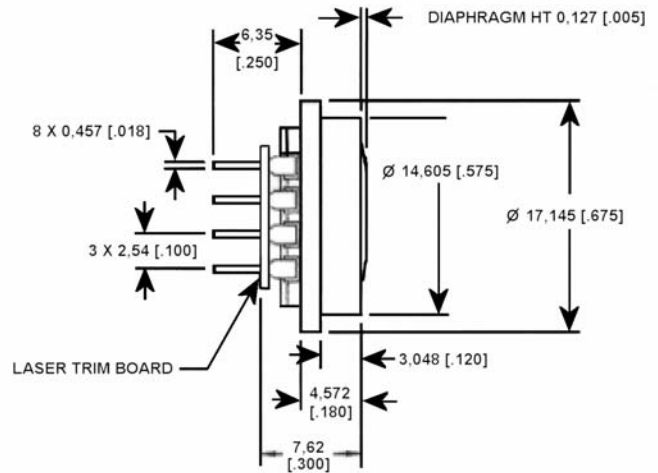
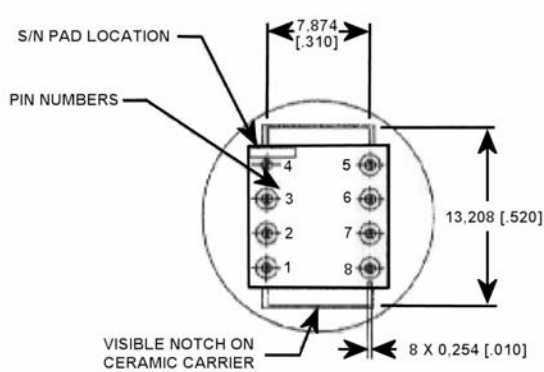

FIGURE 3. LASER TRIM BOARD

Current Excitation, Normalized Output

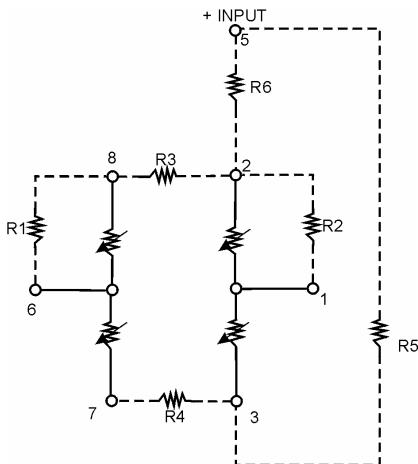
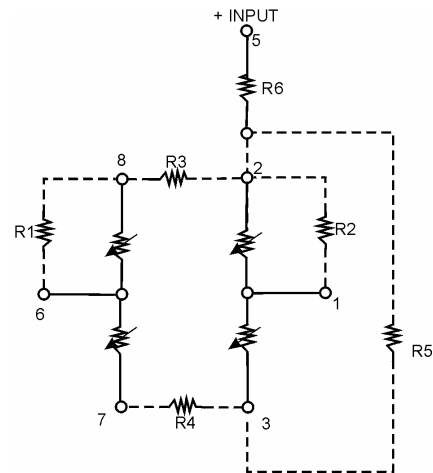

FIGURE 3. LASER TRIM BOARD

Voltage Excitation, Normalized Output



Pressure Sensors

Force/Pressure Transducer

Model 1865 Series

ORDER GUIDE

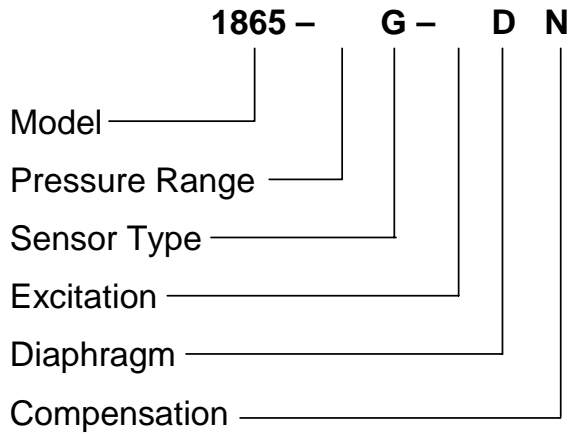

PRESSURE RANGE

01 = 0 psi to 5 psi
02 = 0 psi to 10 psi
03 = 0 psi to 15 psi
05 = 0 psi to 25 psi
07 = 0 psi to 30 psi

SENSOR TYPE

G = Gauge Pressure

EXCITATION

L = 1.5 mA
K = 10 Vdc

DIAPHRAGM TYPE

D = Dimethyl Silicone

COMPENSATION

N = Laser trimmed, normalized output

ACCURACY GUIDE

Higher accuracy grades are available as specials.
Custom configurations are available on request

WARRANTY/REMEDY

Honeywell warrants goods of its manufacture as being free of defective materials and faulty workmanship. Contact your local sales office for warranty information. If warranted goods are returned to Honeywell during the period of coverage, Honeywell will repair or replace without charge those items it finds defective. **The foregoing is Buyer's sole remedy and is in lieu of all other warranties, expressed or implied, including those of merchantability and fitness for a particular purpose.**

Specifications may change without notice. The information we supply is believed to be accurate and reliable as of this printing. However, we assume no responsibility for its use.

While we provide application assistance personally, through our literature and the Honeywell web site, it is up to the customer to determine the suitability of the product in the application.

For application assistance, current specifications, or name of the nearest Authorized Distributor, contact a nearby sales office. Or call:

1-800-537-6945 USA/Canada
1-815-235-6847 International

FAX

1-815-235-6545 USA

INTERNET

www.honeywell.com/sensing
info.sc@honeywell.com

Honeywell

Sensing and Control
www.honeywell.com/sensing

Honeywell
11 West Spring Street
Freeport, Illinois 61032